

Ridgelight at 5° with Beams

TECHNISCHE FICHE

Ridgelight at 5° with Beams (Horizontal beam with rectangular profile)

Ridgelights at 5° pitch guarantee the illusion of a small glass roof with discreet transverse horizontal supporting beams. The prefabricated VELUX beam supports the skylights and creates

the 5° pitch. The beams are mounted on a standard steel profile, 100 mm wide (not a VELUX component), on top of the sub-construction.

Download
CAD & BIM
objects

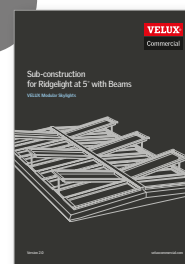
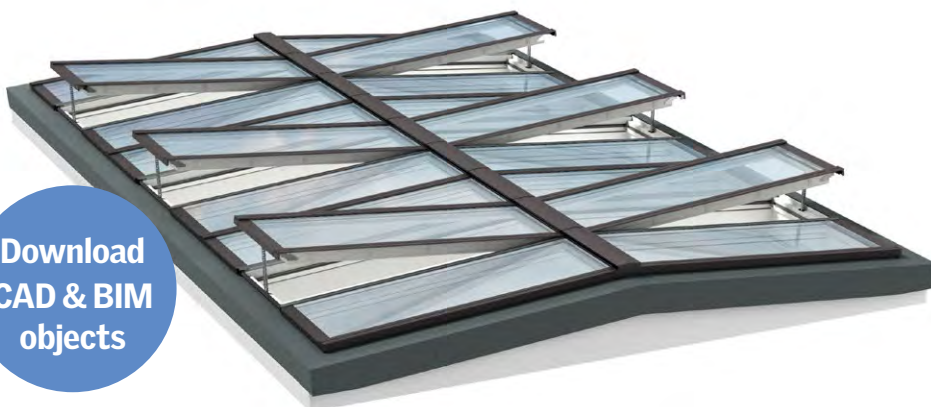

Sub-construction for
Ridgelight at 5° with Beams at:
veluxcommercial.com

Use the table to define module height (H) and/or installation pitch (α).

Example:
A = 4975 mm

Result:
 α : H = 2400 mm at an installation pitch of 5°

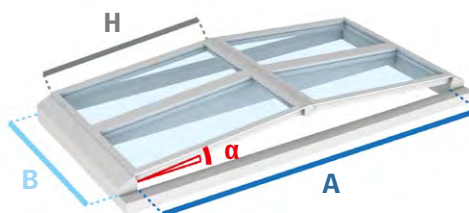

H: Module height
 α : Installation pitch
A: Opening width
B: Opening length

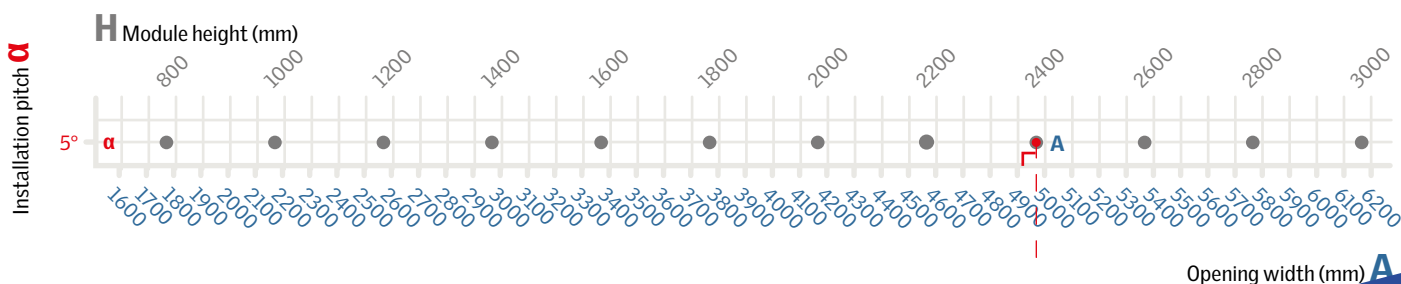

Measurements in the above example are guidelines only. Exact numbers will be supplied by your VELUX sales company.

Ridgelight at 5° with Beams

TECHNISCHE FICHE

Solutions

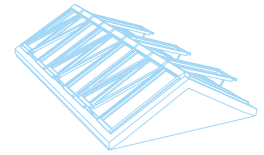

Sectional drawings

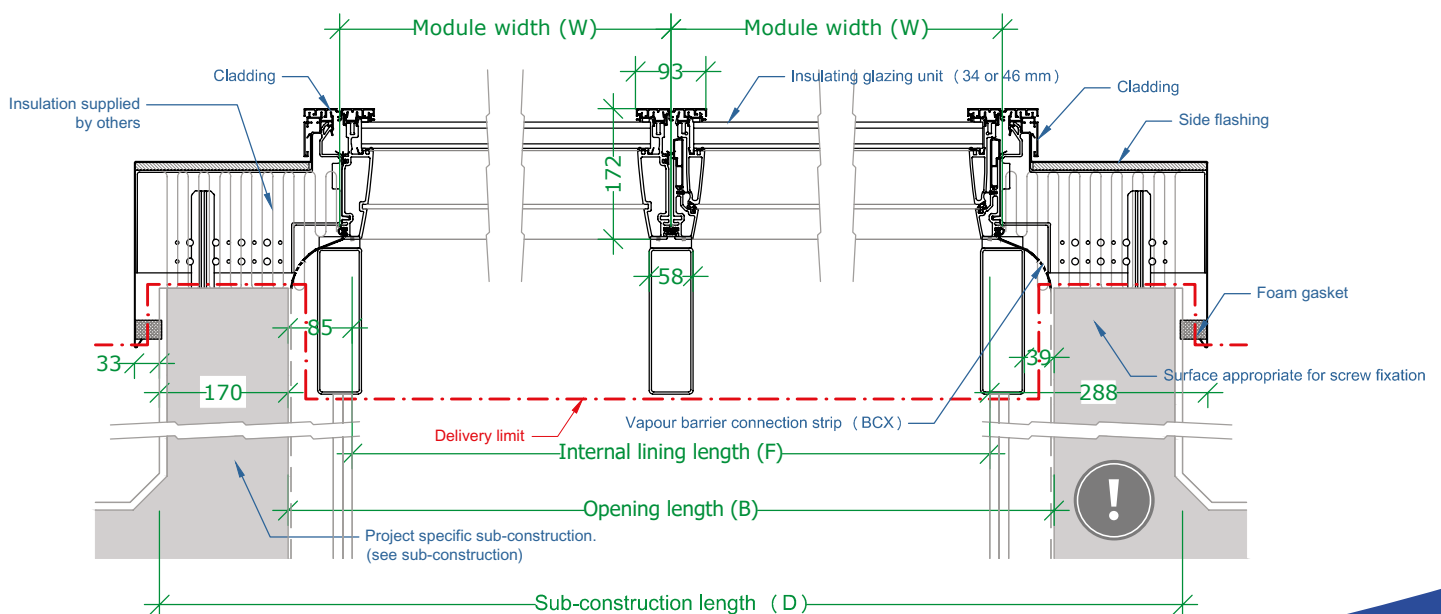
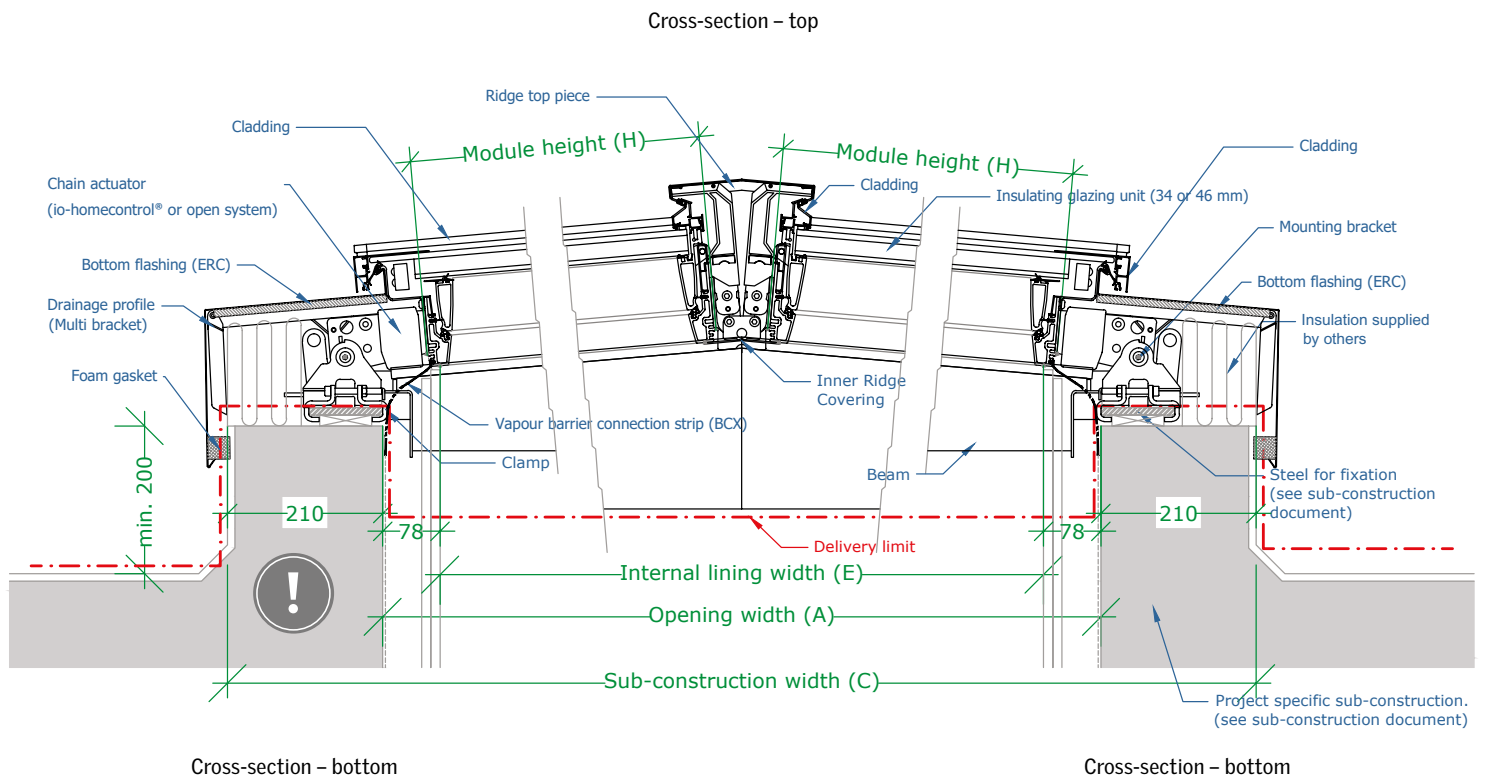

Please observe that a lateral slope on the modules is NOT possible, therefore top and bottom sub-construction must be horizontal.

Ridgelight at 5° with Beams

TECHNISCHE FICHE

Ridgelight at 5° with Beams (Parallel beam with curved profile)

Ridgelights at 5° pitch guarantee the illusion of a small glass roof with discreet transverse parallel supporting beams. The prefabricated VELUX beam supports the skylights and creates

the 5° pitch. The beams are mounted on a standard steel profile, 100 mm wide (not a VELUX component), on top of the sub-construction.

Download
CAD & BIM
objects

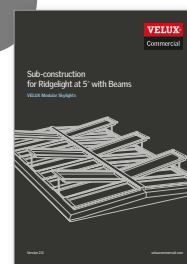
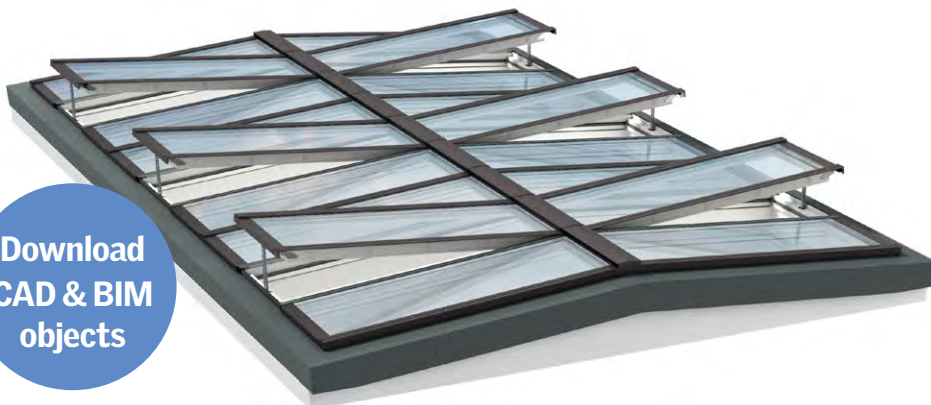

Sub-construction for
Ridgelight at 5° with Beams at:
veluxcommercial.com

Use the table to define module height (H) and/or installation pitch (α).

Example:
A = 4975 mm

Result:
 α : H = 2400 mm at an installation pitch of 5°

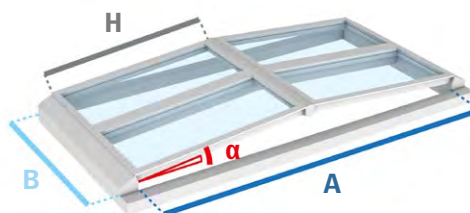

H: Module height
 α : Installation pitch
A: Opening width
B: Opening length

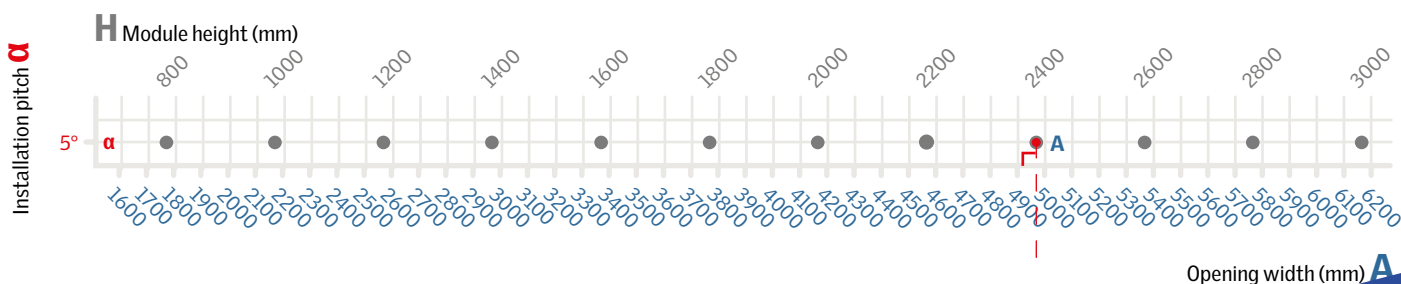

Measurements in the above example are guidelines only. Exact numbers will be supplied by your VELUX sales company.

Ridgelight at 5° with Beams

TECHNISCHE FICHE

Solutions

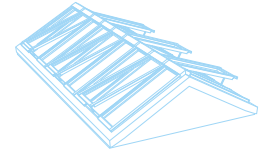

Sectional drawings

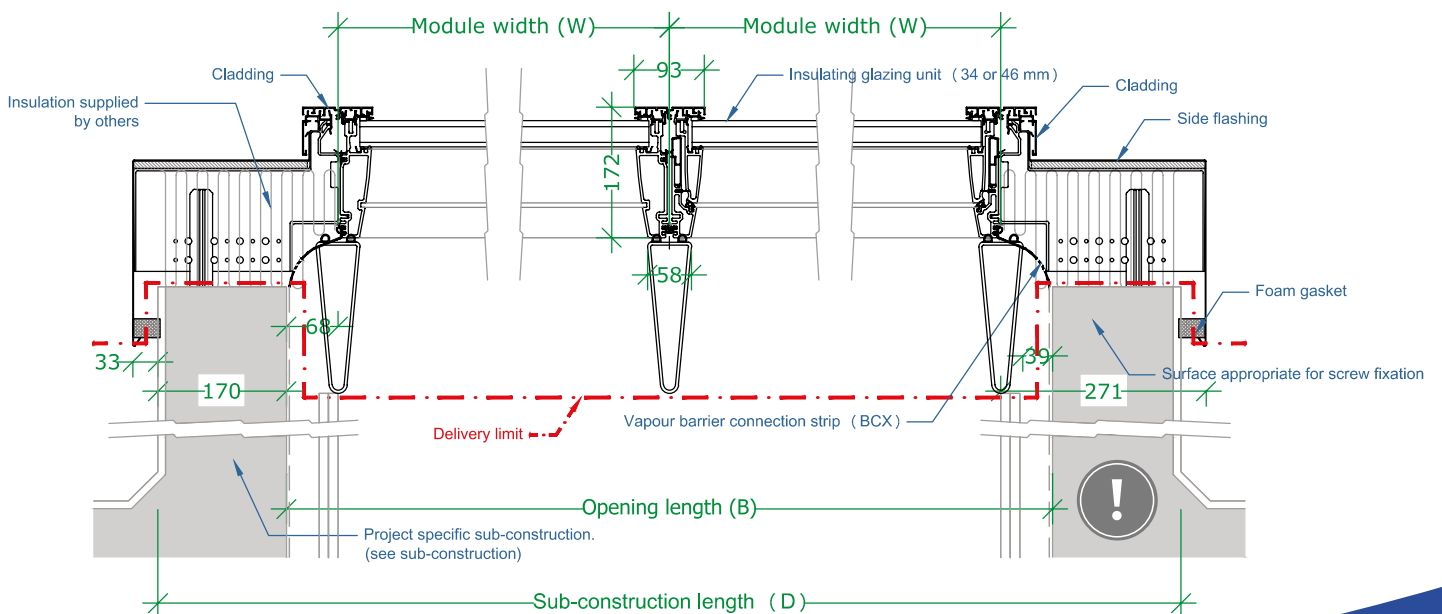
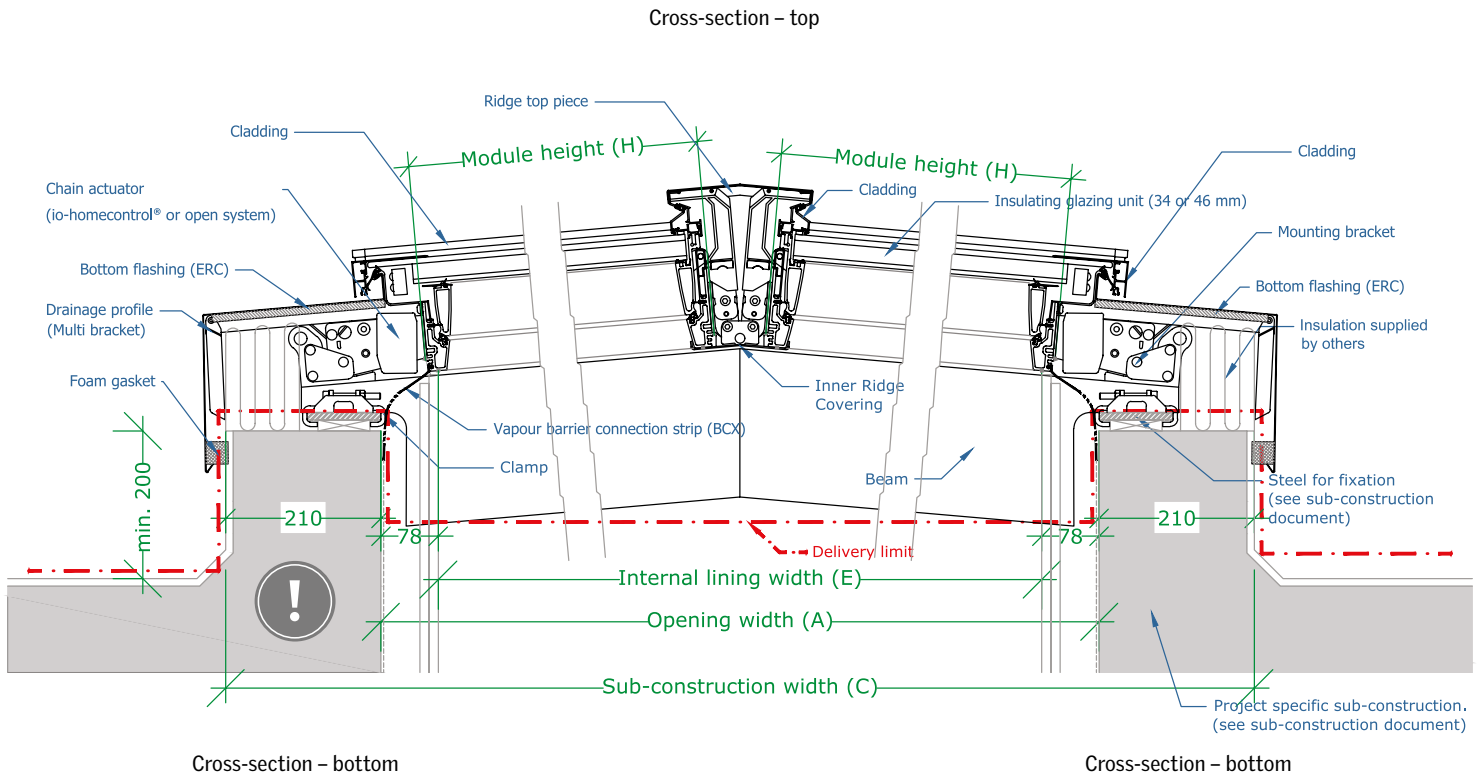

Please observe that a lateral slope on the modules is NOT possible, therefore top and bottom sub-construction must be horizontal.